

# 10K Swing Check Valve

**10SRBF**  
B.C.  
FF-flanged

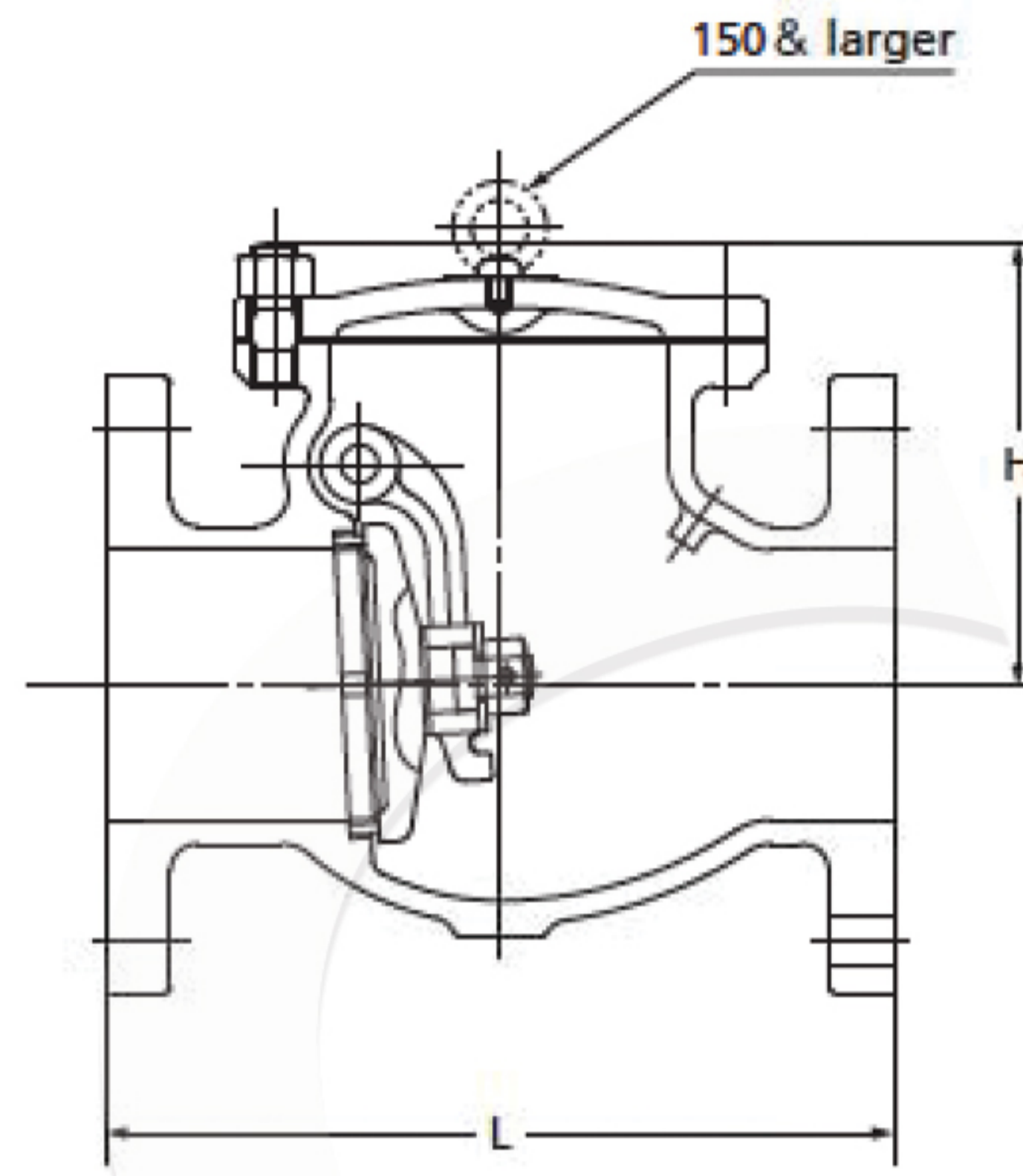

Face to face : JIS B 2002  
End connection : JIS B 2239 10K

120°C Static water..... 1.4MPa  
220°C Steam, air, gas, oil..... 1.2MPa  
300°C Steam, air, gas, oil..... 1.0MPa

- Use for lubricating or hydraulic oil is acceptable. Contact KITZ Corporation for technical advice, if valves are used as heat transfer media.
- Bolting materials will be changed for servicing high temperature exceeding 225°C. Contact KITZ Corporation for detailed information.
- A gasket will be used for sealing the plug for application to high temperature exceeding 260°C. Specify your service temperature in advance. Ensure replacement of plug gaskets on your valve maintenance.

### Materials

Parts	JIS material
Body	FCD-5
Cover	FCD-5
Disc	SUS403 (200 ~ 300 : SCPH2 + 13Cr)
Disc nut	SS400 (125 ~ 300 : SUS304)
Body seat ring	SUS403
Arm	SCS13A (125 ~ 300 : SCHP2)
Hinge pin	SUS403
Split pin	SUS304
Plug	SS400 (125 ~ 300 : S45C)
Washer	SS400 (125 ~ 300 : SUS403)
Gasket	Non-asbestos Sheet
Cover bolt/nut	Carbon Steel

### Dimensions

Size	mm										
	mm	40	50	65	80	100	125	150	200	250	300
	inch	1½	2	2½	3	4	5	6	8	10	12
L		165	203	216	241	292	330	356	495	622	698
H		115	120	130	145	160	195	215	255	310	350

NOTE : For flange dimensions, refer to Page 44. ※RF-flanged ends shall be optionally available.